

Roy E. Pafenberg W4WKM
316 Stratford Avenue
Fairfax, Virginia

73 Tests

The Knight T-60 Xmitter

A 60 watt AM and CW transmitter with full 80 through 6 meter amateur band coverage for less than \$50.00? It's hard to believe but this is what Allied Radio Corporation has accomplished in their new transmitter kit. The Knight T-60 is a completely self-contained, neat little package that puts out an amazing signal for its size.

A quick check of the specifications will verify that this easy to assemble kit is a real bargain on today's amateur equipment market. How does this Knight-Kit provide so many features at the price of \$49.95? Part of the

reason is, of course, that it is a kit; you supply the majority of the labor. That is, if you call the interesting, easy assembly of the transmitter labor. The design concepts that provide high performance at low cost include a silicon rectifier power supply, use of a mass produced, high efficiency TV sweep tube in the output stage and a highly effective, controlled carrier screen modulation system that provides good quality speech with plenty of punch. This audio system allows the final to loaf along at about $\frac{1}{4}$ normal power input and still approach the CW input of 60 watts on voice peaks.

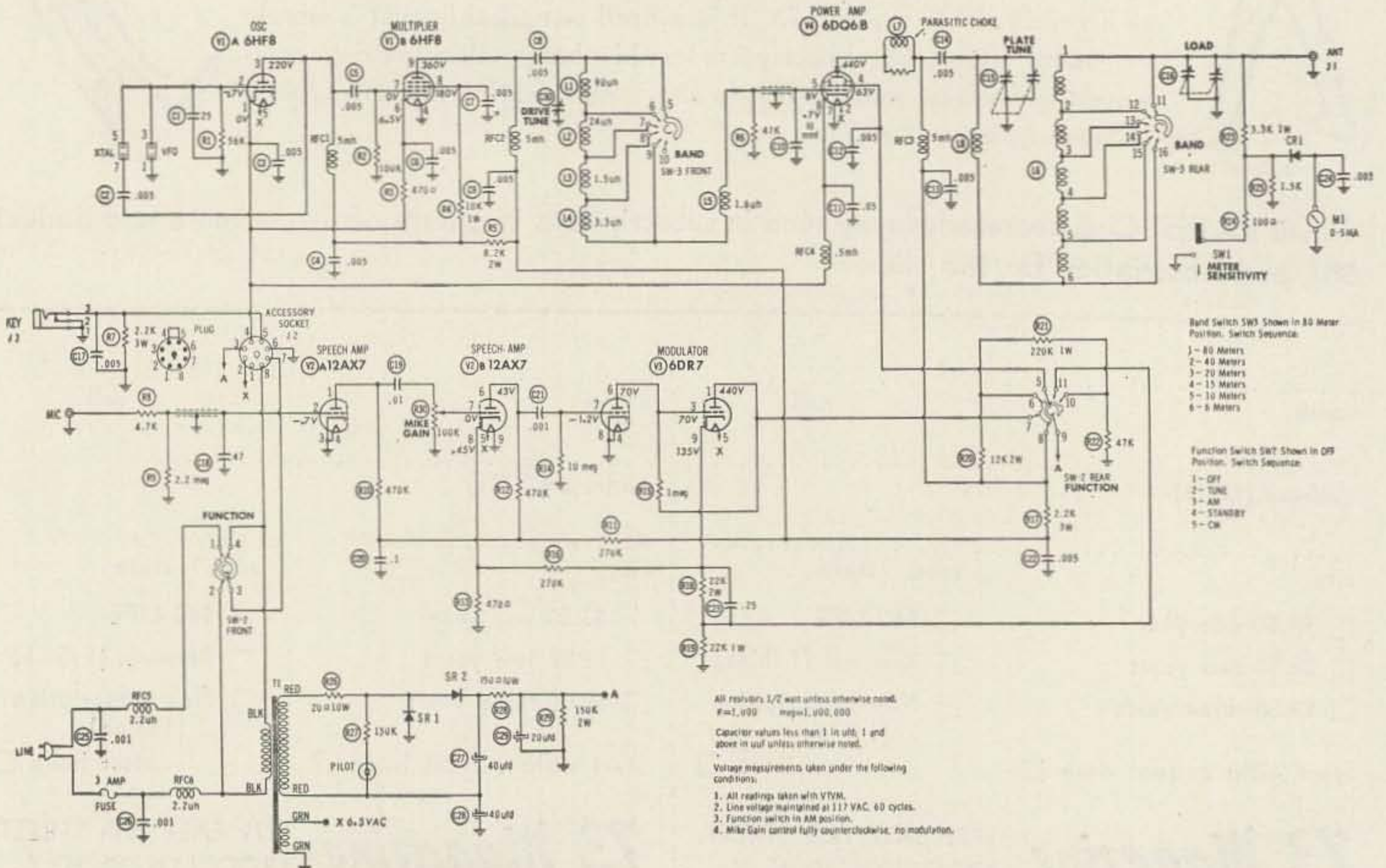

These same features make compact construction possible and this little transmitter is no larger than a man-size shoe box. The gray wrinkle finished, rugged steel cabinet and the two-tone panel provide a very attractive and practical housing. Despite the compact construction, assembly is easy.

The 218 separate assembly steps are arranged in easy to understand, check-off order in the large 8½" x 11", well printed instruction manual. This 32 page booklet contains 19 clear illustrations in addition to the schematic diagram and complete illustrated parts breakdown. As a further construction aid, 6 of the major assembly illustrations are duplicated in 15" x 20" wall chart form. With all of this assistance, it is indeed difficult to goof.

Good quality parts are used throughout the transmitter and packaging of the parts is geared to convenient assembly. Resistors are card mounted and are marked for ready selection. Other small parts are supplied in transparent plastic bags for easy identification. These features, along with the illustrated parts breakdown, detailed drawings and self-checking instructions make for rapid assembly by even the most inexperienced individual.

The schematic diagram of the T-60 transmitter is shown in Figure 1. The circuit consists of a 6HF8 triode section (V1A) operating as a Pierce crystal oscillator or as a VFO amplifier. The pentode section of the 6HF8 (V1B) is used as a buffer amplifier or frequency multiplier, depending on the band in use. An adjustable pi network tuned circuit is used to couple the buffer-multiplier stage to the grid of the 6DQ6B (V4) power amplifier stage. The plate of the 6DQ6B is shunt fed and a pi network used to provide the proper match between the high impedance plate circuit and the antenna. Antennas with impedances ranging between 40 and 600 ohms can be matched with this network. Figure 2 charts the frequency coverage of the transmitter along with the recommended crystal or external VFO frequencies for each band.

The metering circuit of the T-60 follows the trend established in several recent transmitters. A crystal diode, CR1, is used to rectify a portion of the RF present at the output of the antenna network. The filtered output of the diode is applied to the meter and a shunt resistor may be switched in to avoid off-scale deflection of the meter when feeding high impedance loads. The DRIVE TUNE, PLATE TUNE and LOAD controls are all adjusted for maximum meter deflection with the FUNCTION switch in the tune position. The switch is then thrown to the CW position and the controls peaked for maximum output. While this may appear to be a quick and dirty method of metering a 3 stage transmitter, it really works well and permits easy, accurate tuning by inexperienced operators.

SECO 520 ANTENNA ANALYZER

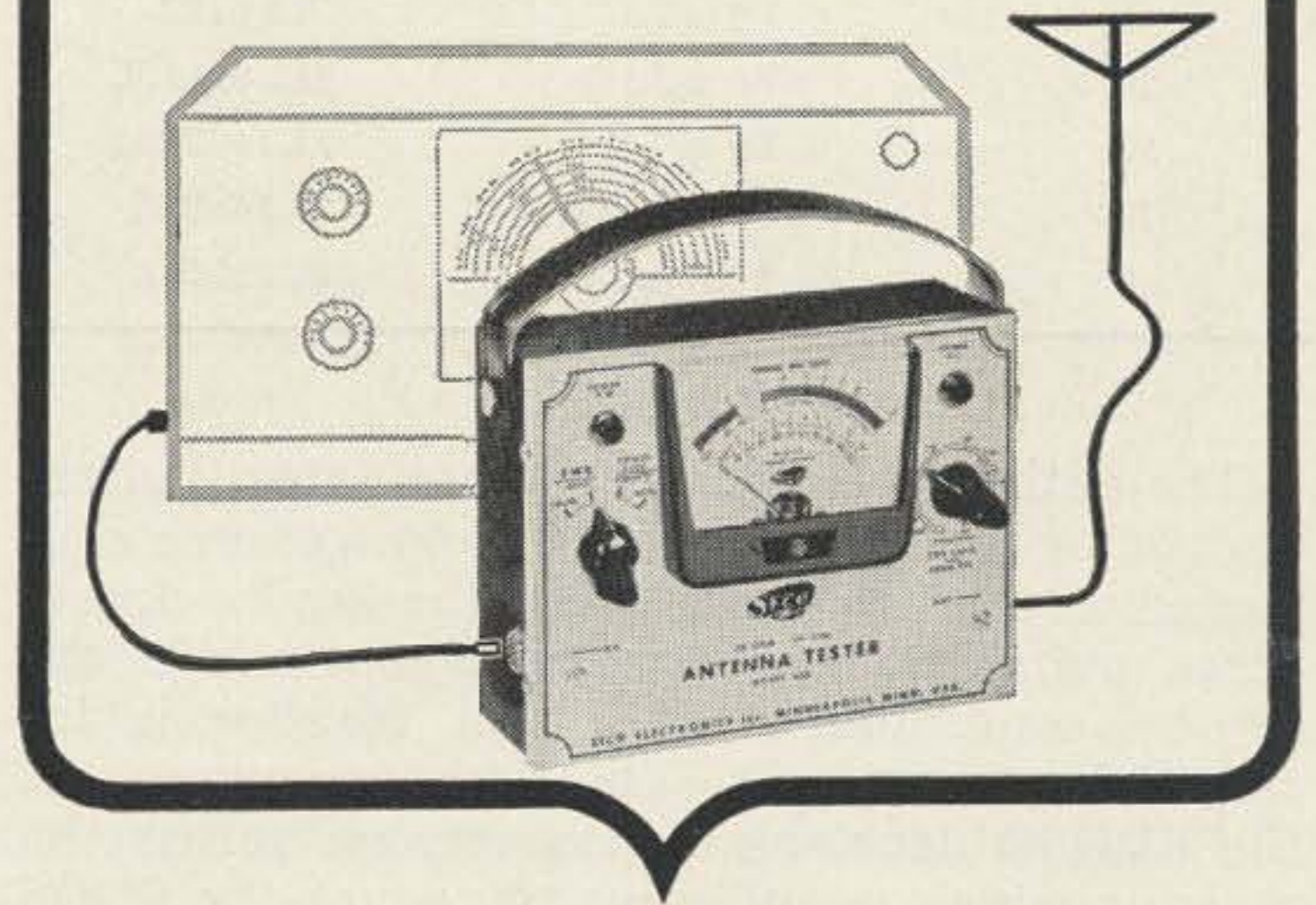

HAMS . . . this Seco 8-point antenna and power amplifier check gets more from your rig

1. Is my antenna radiating all available power?
2. Are there "Hot Spots" in my feed line?
3. Is my antenna-feed line match actually tested, or only computed?
4. What is my Forward Power?
5. What is my Reflected Power?
6. Do I have high RF resistance in splices, connectors and in series with the radiating element?
7. What is my RF Power Amplifier Efficiency?
8. How much power am I wasting in relays, filters and feed line?



\$42.95 NET

Analyze Your Antenna and RF Power Amplifier With the SECO 520

3 VSWR scale interpretations—1:1 to 8:1 Standing Wave Ratio—antenna system efficiency—GOOD-BAD scale.

3 Forward and 3 Reflected Power scales accurately calibrated (3.5 to 180 mc)—ranges 0-10, 0-100 and 0-1000 watts.

Directional Coupler and Meter are matched pair, accurately calibrated.

Single compact case 6¾" x 2¼" x 5¼"—no charts or graphs to read.

Scales are calibrated for 50 ohm line (simple multiply reading by 1.4 for 72 ohm lines).

Continuous duty—may be left in line as RF monitor.



SECO ELECTRONICS, INC.

5041 Penn Ave. So., Minneapolis 19, Minn.

Please send me full information on the Seco 520 also Seco electronic equipment catalog folder.

NAME _____

ADDRESS _____

CITY _____ STATE _____

Band (Meters)	Frequency of Crystal or VFO (MC)	Transmitter Freq. Range (MC)
80	3.5 to 4.0	3.5 to 4.0
40	7.0 to 7.3	7.0 to 7.3
20	7.0 to 7.175	14.0 to 14.35
15	7.0 to 7.150	21.0 to 21.45
10	7.0 to 7.425	28.0 to 29.7
6	8.334 to 9.0	50.0 to 54.0

The cathode circuits of the oscillator, buffer-multiplier and power amplifier stages are connected to the key jack. When the key is closed, these points are at ground potential. In the key-up condition, a 2.2K ohm resistor is inserted in the circuit. The cathode current of the 6DQ6B develops a bias voltage across the resistor which is sufficient to reduce the 6DQ6 plate and screen currents to a safe value and completely cut off the oscillator and buffer stages. This design feature reduces the voltage across the open key to a safe value and provides excellent keying characteristics. There is one disadvantage to this keying circuit. If an external VFO is used, it must run continuously and keying must be accomplished in the transmitter.

In the AM mode, a cascaded 12AX7 (V2) is used as a speech amplifier which drives the first section of the 6DR7 (V3) modulator stage. This section of the modulator is operated at zero bias and grid rectification of the applied audio signal occurs. This increase in bias causes the plate voltage to rise, varying with the modulating signal. The grid of the second section is connected to the plate of the input section and this positive voltage rise increases the cathode current, and thus the voltage, of the output stage. A portion of this voltage is applied to the 6DQ6B screen. This voltage rises with modulation and varies at an audio rate, modulating the screen of the rf output amplifier and increasing the average dc potential of the screen. In the TUNE position of the FUNCTION switch, reduced screen voltage is applied to the 6DQ6B and out of resonance plate current is reduced to a safe value.

The power supply is conventional and consists of a power transformer with plate and filament windings. A full wave voltage doubler circuit, using silicon rectifiers and an RC filter develops 440 volts dc for the plate and screen circuits.

The completed transmitter was bench tested, using an M. C. Jones Type 625 wattmeter as a 50 ohm load with the internal indicator used to measure power output on 6 meters. Since the directional coupler used in this instrument is frequency sensitive, a Hewlett-Packard 41

OB VTVM was used to measure the voltage across the load and power output computed for the other bands. PA stage input power was metered and, with the transmitter tuned for maximum output in accordance with the instructions, found to range between 63 watts on 80 meters and 76 watts on 10 meters. Using *active* crystals, CW power output ranged between 40 watts on 80 meters and 26 watts on 10 meters. Efficiency on 6 meters is of course greatly reduced since the PA is operating as a doubler. Measured power output on 6 meters was 13 watts with 80 watts input. It must be emphasized that these measurements were made by tuning in accordance with the instructions, letting the operating conditions fall as they would.

A 1000 cycle tone was applied to the microphone input and a scope connected to monitor the rf envelope. The gain control was advanced to the point where distortion was apparent. This occurred at between 90 and 100% modulation, depending on tuning and loading. Measured *peak* power output was roughly equal to the CW output for identical tuning and loading conditions.

On the air tests produced good results. No attempts were made to establish any DX records, the objective being to obtain critical reports on signal quality. Comments on the controlled carrier modulation system were typical. "Your audio quality is good, OM, but your carrier seems to be going up and down." Those operators familiar with controlled carrier AM signals gave good reports. Constructive, "on the air" help in finding the proper setting of the audio gain control was difficult to obtain. The proper point, verified by the scope, is just below the setting where audio distortion becomes noticeable.

There are very few complaints with the transmitter. The comments on the metering system can not be taken too seriously since the system works and works well. The reduced output on 6 meters is more serious. However, since 6 meter coverage is a bonus anyway, we can afford to be philosophical and not look a gift horse in the mouth. The writer has personal objection to the RCA phono jack used as the mike connector and it is suspected that many will change it to a type to fit their microphones.

All in all, the Knight T-60 is a very good buy. For the Novice, it is an ideal first transmitter and it is very attractive to the more experienced amateur as an emergency or standby unit. The rugged construction and simplicity of the unit make it probable that this little rig will be in service long after more sophisticated equipment is "down for maintenance."

... W4WKM